



Parts List
4" Model AAT-18 and AAT-27
Auto-Adjust® II Turbo-Meters

Parts List
4" Model AAT-18 and AAT-27
Auto-Adjust® II Turbo-Meters

Working Pressures:

175, 275, 720 & 1440 psi

4" MODEL AAT-18 AND AAT-27 AUTO-ADJUST® II TURBO-METERS

GENERAL ASSEMBLY

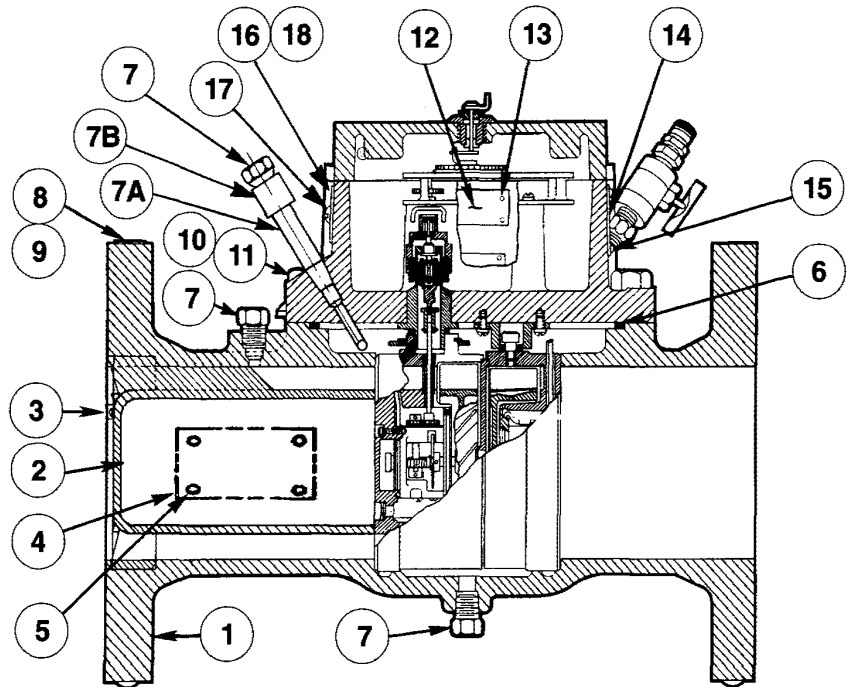

Body Assembly Components

ILL. NO.	QTY. REQ'D	PART DESCRIPTION	PART NUMBER
**1	1	Main Body Assy., Aluminum, 175# W.P., w/ Badges Less Nose Cone	006-22-611-00
		Main Body Assy., Cast Steel, ANSI 150, 275# W.P., w/ Badges Less Nose Cone	006-22-611-02
		Main Body Assy., Cast Steel, ANSI 300, 720# W.P., w/ Badges Less Nose Cone	006-22-611-50
		Main Body Assy., Cast Steel, ANSI 600, 1440# W.P., w/ Badges Less Nose Cone	006-22-611-80
		Main Body Assy., Cast Steel, ANSI 600, 1440# W.P., w/ Badges Less Nose Cone, w/Ring Joint Flanges	006-22-611-81
2	1	Nose Cone With Straightening Vanes, All Pressures	006-22-305-03
3	3	Nose Cone Retainer, #8-32 x 3/8" Long Truss Head Stainless Steel Machine Screw	950426
4	1	Mfg. Nameplate, 175# W.P.	AAT-18 006-22-073-01-555
		Mfg. Nameplate, 275# W.P.	AAT-18 006-22-073-30-555
		Mfg. Nameplate, 720# W.P.	AAT-18 006-22-073-51-555
		Mfg. Nameplate, 1440# W.P.	AAT-18 006-22-073-90-555
		Mfg. Nameplate, 175# W.P.	AAT-27 006-42-073-01-555
		Mfg. Nameplate, 275# W.P.	AAT-27 006-42-073-30-555
		Mfg. Nameplate, 720# W.P.	AAT-27 006-42-073-51-555
5	4	Mfg. Nameplate, 1440# W.P.	AAT-27 006-42-073-90-555
		Manufacturer Nameplate Drive Screw, #4 x 3/16" Long Round Head, Brass	903004
		Top Plate to Body, "O" Ring, 175# W.P., Buna	934338
		Top Plate to Body, "O" Ring H.P. Viton	906089
*6	1	Top Plate to Body, "O" Ring, H.P.	950189
		Steel Pipe Plug, 1/4"	906055
		7A	1
7B	1	1/4" Steel Coupling, #720 & 1440# W.P.	950711
8	1	Inlet Badge (On Inlet Flange of Body)	015-16-090-02
9	2	Inlet Badge Drive Screws, #2 x 1/8" Round Head, Brass	903003
10	1	Inlet Badge (On Top Plate)	006-22-073-04
11	2	Inlet Badge Drive Screw, #0 x 1/8"	903001
12	1	Internal Mechanism Badge	006-32-073-02
13	4	Internal Mechanism Drive Screws, #0 x 1/8"	903001
		14	1
14	1	C.S.A. Badge	AAT-27 006-42-074-00
		C.S.A. Manufacturer Nameplate Drive Screw, #2 x 1/8" Long	903003
15	4	C.S.A. Manufacturer Nameplate Drive Screw, #2 x 1/8" Long	903003
16	1	Badge, Pulse Factor Ft³	006-32-073-10
17	2	#8-32 x 1/4" Long Round Head Stainless Steel Machine Screw	903055
18	1	Badge, Pulse Factor M³	006-32-073-11

* Recommended Spare Parts

2 ** Main Body Assembly, Includes Inlet and Body Badges Less Nose Cone

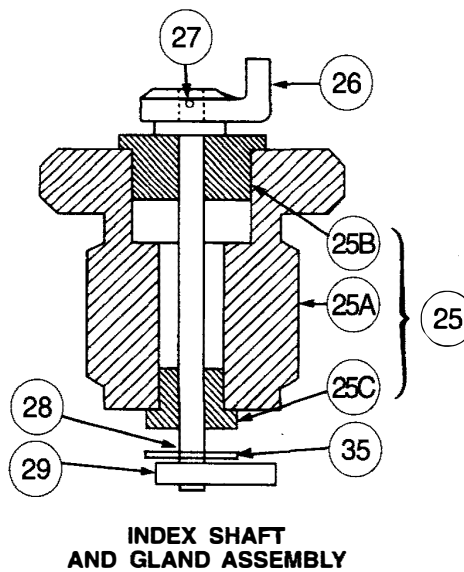
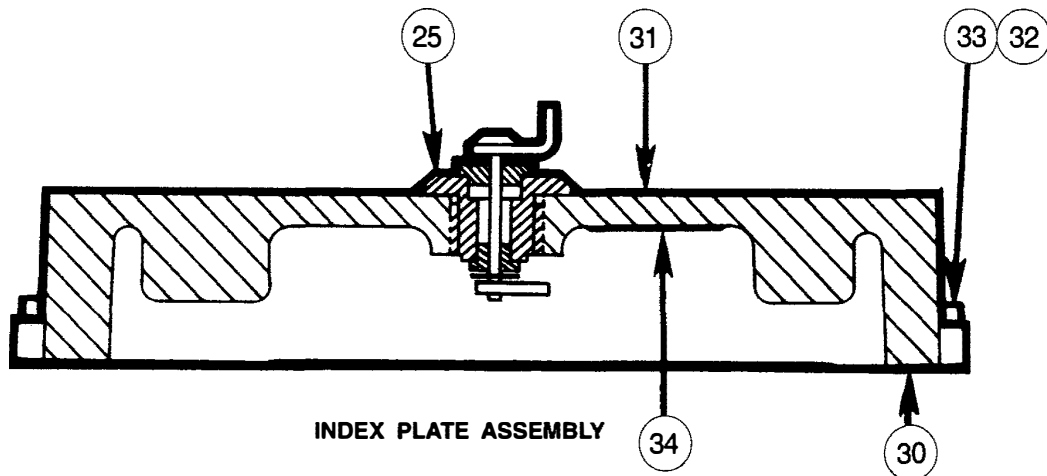

Index Plate Assembly Components

ILL. NO.	QTY. REQ'D	PART DESCRIPTION	PART NUMBER
25	1	Index Shaft Gland Assembly (Includes Illustration Nos. 25 A-C)	006-24-323-00
25A	1	Gland	006-24-023-00
25B	1	Bushing (Top)	006-24-052-01
25C	1	Bushing (Bottom)	001-60-052-62
26	1	Top Index Shaft Dog	006-24-061-04
*27	1	Shear Pin, Top Index Shaft Dog	006-24-056-00
28	1	Index Shaft	006-24-054-02
29	1	Bottom Index Shaft Dog	006-24-071-00
*30	1	Gasket, Index Plate to Top Plate	006-24-160-03
31	1	Index Plate	006-24-504-21
32	3	Cap Screw, Index Plate to Top Plate, $\frac{5}{16}$ " -18 x $\frac{3}{4}$ " Hex. Hd.	910028
33	1	Seal Cap Screw, Index Plate to Top Plate, $\frac{5}{16}$ " -18 x $\frac{3}{4}$ " Hex. Hd.	002-65-057-02
34	1	Wiring Label	006-32-105-00
35	1	Retaining Ring	950578

*Recommended Spare Parts

4" MODEL AAT-18 AND AAT-27 AUTO-ADJUST® II TURBO-METERS

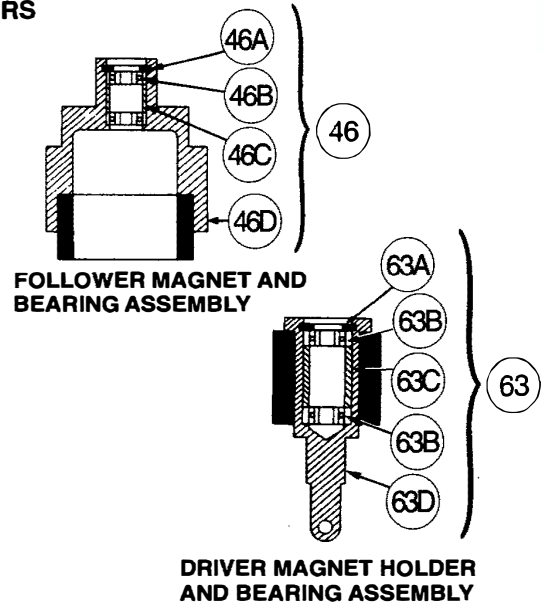
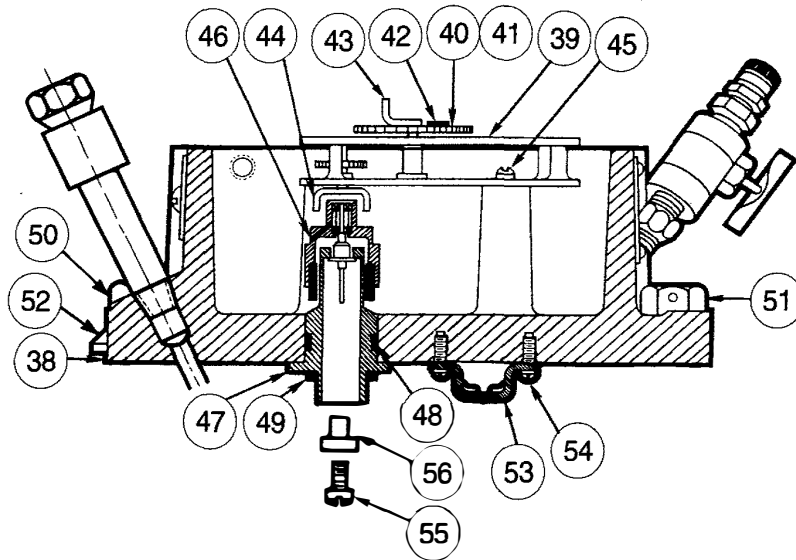

Top Plate Assembly—Mechanical Components

ILL. NO.	QTY. REQ'D	PART DESCRIPTION	PART NUMBER
38	1	Top Plate Assembly, Aluminum, 175# W.P.	006-32-303-20
		Top Plate Assembly, Steel ANSI 150, 275# W.P.	006-32-303-31
		Top Plate Assembly, Steel ANSI 300, 720# W.P.	006-32-303-81
		Top Plate Assembly, Steel ANSI 600, 1440# W.P.	006-32-303-81
*39	1	Intermediate Gear Assembly, 100 CF ³ /Rev. Plastic	006-32-212-40
		Intermediate Gear Assembly, 10 M ³ /Rev.	006-32-212-02
		Intermediate Gear Assembly, 1M ³ /Rev.	006-32-212-42
40	1	Large Change Gear [Note: "XX" Refers to Gear Blank (Diameter) Size, "YY" Refers to Number of Gear Teeth. Digits Must be Substituted for "XX" and "YY" When Ordering]	006-24-3XX-YY
41	1	Small Change Gear (See Note for No. 40 Above)	006-24-3XX-YY
42	1	Small Change Gear Nut, #4-40 Hexagonal Stainless Steel	907639
43	1	Intermediate Gear Output Dog (Top)	002-66-071-03
44	1	Intermediate Gear Input Dog (Bottom)	006-24-061-20
45	3	Intermediate Gear Retaining Screws. #8-32 x 3/8" Long Fillister Head Stainless Steel	903371
*46	1	Follower Magnet Assembly (Including Illustration Nos. 46A-D)	006-24-313-20
46A	1	Retaining Ring	904691
46B	2	Bearing	905462
46C	1	Spacer	006-24-106-20
46D	1	Follower Magnet Holder Assembly With Magnet	006-24-213-20
*47	1	Driver Magnet Well and Post Assembly, 175# & 275# W.P. (Includes Illustration No. 48)	006-31-244-00
		Driver Magnet Well and Post Assembly, 720# & 1440# W.P. (Includes Illustration No. 48)	006-24-244-20
*48	1	Driver Magnet Well "O" Ring	950193
		Driver Magnet Well "O" Ring, Viton	908264
*49	1	Driver Magnet Well Tetraseal	904214
		Driver Magnet Well Tetraseal, Viton	906736
50	7	Cap Screw, Top Plate to Body, 175# W.P., 1/2"-13 x 1 1/4" Long Hex. Hd.	910106
		Cap Screw, Top Plate to Body, 275# W.P., 1/2"-13 x 1 1/4" Long Hex. Hd.	903592
		Cap Screw, Top Plate to Body, 720# & 1440# W.P., 3/4"-10 x 2" Long Hex. Hd.	935678
51	1	Seal Cap Screw, Top Plate to Body, 175# W.P., 1/2"-13 x 1 1/4" Long Hex. Hd.	006-22-056-00
		Seal Cap Screw, Top Plate to Body, 275# W.P., 1/2"-13 x 1 1/4" Long Hex. Hd.	002-66-057-10
52	2	Seal Cap Screw, Top Plate to Body, 720# & 1440# W.P., 3/4"-10 x 2" Long Hex. Hd.	006-22-058-00
		Vent Cap Assembly	006-24-505-01
53	1	Extractor Bracket Assembly	006-32-304-01
54	2	Block Retaining Screws. #8-32 x 3/8" Long Fillister Head Stainless Steel Machine Screw	903371
55	2	Adapter Plate Screw. #8-32 x 3/4" Fillister Head	906847
56	2	Bushing	066-32-113-01

*Recommended Spare Parts

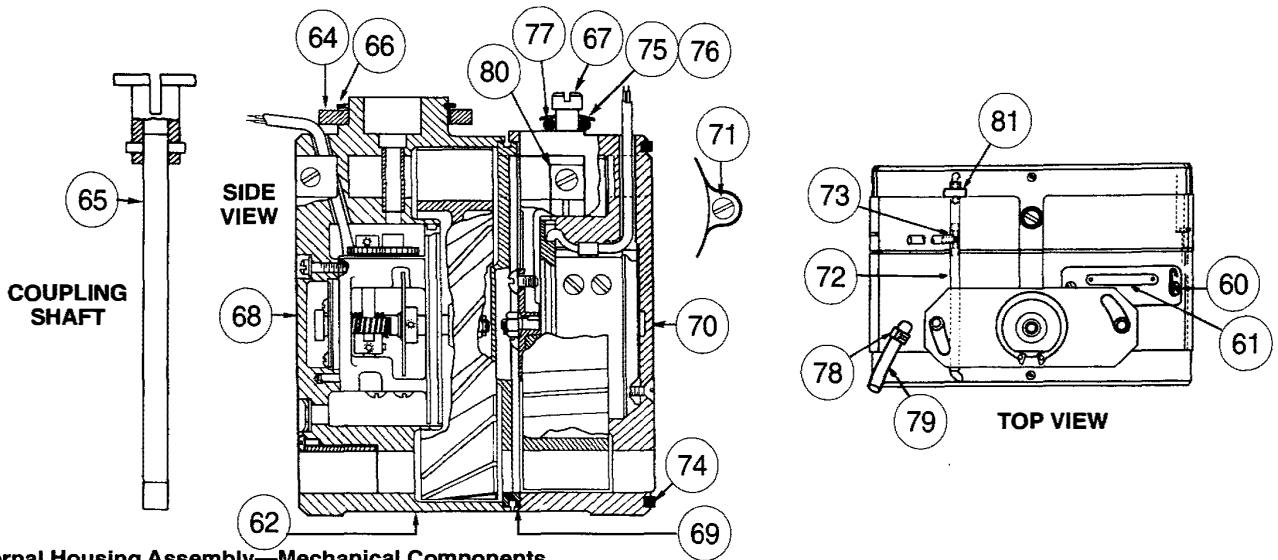

Internal Housing Assembly—Mechanical Components

ILL. NO.	QTY. REQ'D	PART DESCRIPTION	PART NUMBER
60	2	#4-40 x 1/4" Pan Head Stainless Steel Machine Screw	950380
61	1	Serial No. Badge	006-34-073-01
62	1	Internal Housing Assembly, Calibrated With Change Gears, 175# W.P., Cubic Foot	AAT-18 006-32-302-02
		Internal Housing Assembly, Calibrated With Change Gears, 175# W.P., Metric	AAT-18 006-32-302-03
		Internal Housing Assembly, Calibrated With Change Gears, H.P., Cubic Foot	AAT-18 006-32-302-80
		Internal Housing Assembly, Calibrated With Change Gears, H.P., Metric	AAT-18 006-32-302-81
		Internal Housing Assembly, Calibrated With Change Gears, 175# W.P., Cubic Foot	AAT-27 006-42-302-02
		Internal Housing Assembly, Calibrated With Change Gears, 175# W.P., Metric	AAT-27 006-42-302-03
		Internal Housing Assembly, Calibrated With Change Gears, H.P., Cubic Foot	AAT-27 006-42-302-80
		Internal Housing Assembly, Calibrated With Change Gears, H.P., Metric	AAT-27 006-42-302-81
*63	1	Driver Magnet Holder & Bearing Assembly (Includes Illustration Nos. 63 A-D)	006-31-334-00
63A	1	Bearing Retaining Ring	904691
63B	2	Bearing	905462
63C	1	Spacer	006-22-106-03
63D	1	Driver Magnet & Pin Assembly	006-31-234-02
64	1	Adapter Plate	006-32-062-01
65	1	Coupling Shaft Assembly, 175# & 275# W.P.	006-32-345-00
		Coupling Shaft Assembly, 720# & 1440# W.P.	006-32-345-80
66	1	Retaining Ring	904435
67	1	Shoulder Screw	950319
†68	1	Main (Metering) Rotor Assembly	AAT-18 006-32-550-02
		Main (Metering) Rotor Assembly	AAT-27 006-42-550-02
†69	1	Center Plate	AAT-18 006-32-109-03
		Center Plate	AAT-27 006-42-109-03
†70	1	Sensor Rotor Assembly	AAT-18 006-32-550-03
		Sensor Rotor Assembly	AAT-27 006-42-550-03
71	2	#4-40 x 5/8" Long Fillister Head Stainless Steel Machine Screw	950456
72	AR	Tubing For Lubrication System	99993
73	1	Tee, 1/8" Polypropylene	950247
74	1	Tetraseal, Viton	950479
75	1	"O" Ring, Buna	934005
76	1	"O" Ring, Viton	904839
77	1	Disc Spring	950749
78	2	Compression Ring	AAT-18 950772
79	.5'	Pressure Tubing	AAT-18 800700
80	1	Clip For Wires	950517
81	3	Compression Ring Lubricant	950682
82	1	Oil Tube Replacement Assembly (Not Shown)	006-32-325-00
83	1	Retrofit Adapter Kit (Not Shown)	006-32-190-00

*Recommended Spare Parts

†S.O.—302 Only. Illustration Nos. 68, 69 and 70 affect calibration. These components must be ordered in combination as a 302 Assembly and cannot be supplied as separate items.

†These items affect calibration and must be ordered in combination with Sensor Rotor Assembly, Center Plate and Internal Housing, as a 302 Assembly.

4" MODEL AAT-18 AND AAT-27 AUTO-ADJUST® II TURBO-METERS

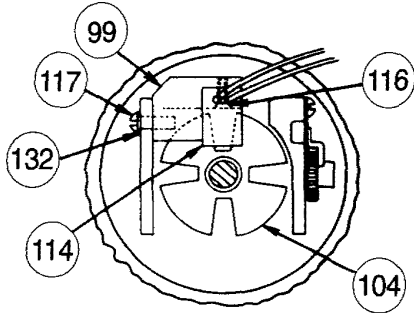

SECTION A-A

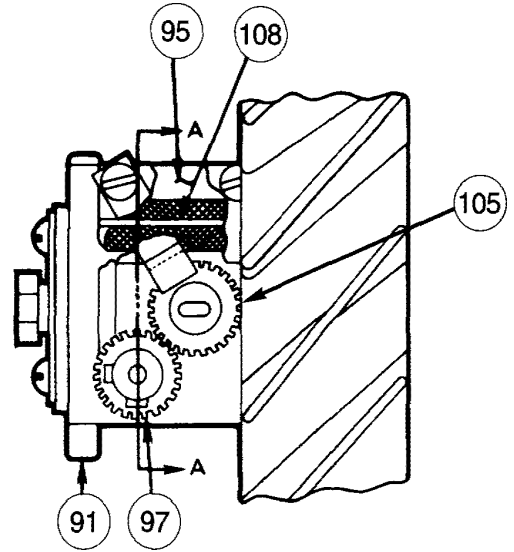

TOP VIEW
BEARING BRACKET

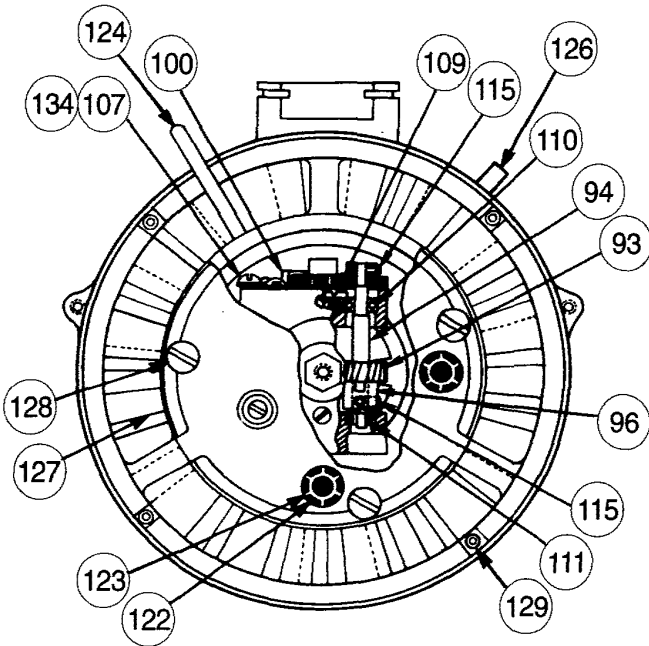

INLET VIEW

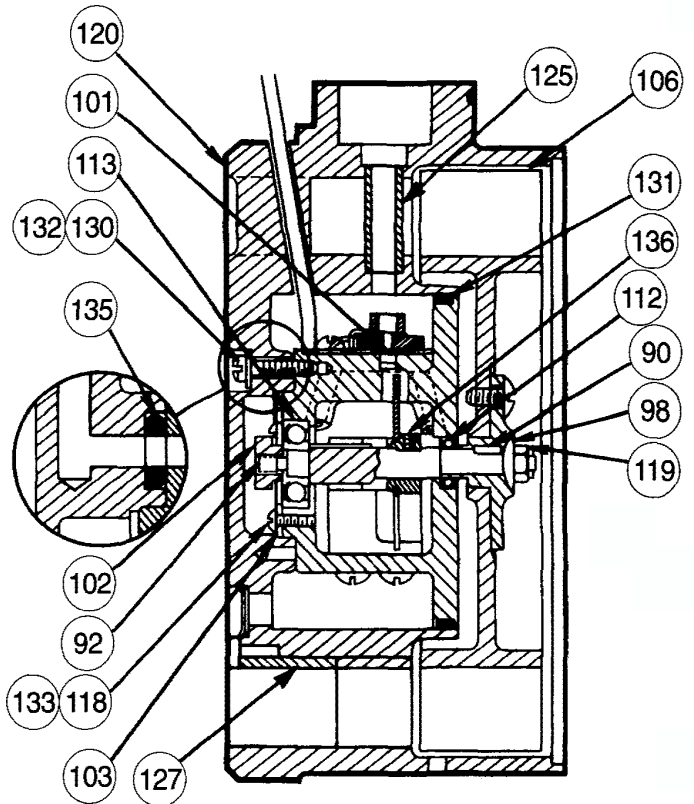

SIDE VIEW

Main (Metering) Rotor Assembly Components

ILL. NO.	QTY. REQ'D	PART DESCRIPTION	PART NUMBER
†	1	Main Rotor Assembly (Includes Illustration Nos. 90-136)	AAT-18 006-32-550-02
		Main Rotor Assembly (Includes Illustration Nos. 90-136)	AAT-27 006-42-550-02
90	1	Locking Pin	006-22-020-00
91	1	Bearing Bracket & Pin Assembly	006-32-221-00
92	1	Shaft (Main Rotor) w/ Worm	AAT-18 006-32-024-00
		Shaft (Main Rotor) w/ Worm	AAT-27 006-42-024-00
93	1	Wormwheel	AAT-18 006-32-035-00
		Wormwheel	AAT-27 006-42-035-00
94	1	Shaft (Wormwheel)	006-32-046-00
95	1	Cover (Oil Reservoir)	006-32-053-01
96	1	Hub (Wormwheel)	006-32-070-00
97	1	Drive Gear	AAT-18 006-32-428-00
		Drive Gear	AAT-27 006-32-428-01
98	1	Spherical Washer (Main Shaft)	006-32-077-01
99	1	Sensor Holder	006-32-078-01
100	1	Gear Retainer	006-32-080-00
101	1	Gear Post	006-32-081-00
102	1	Retaining Nut	006-32-084-00
103	1	Bearing Retainer	006-32-117-01
104	1	Chopper Assembly	006-32-308-00
105	1	Upshaft Gear	AAT-18 006-32-330-00
		Upshaft Gear	AAT-27 006-32-330-01
†106	1	Rotor & Hub Assembly	AAT-18 006-32-350-04
		Rotor & Hub Assembly	AAT-27 006-42-350-04
107	2	#4-40 x 1/4" Long Round Head Stainless Steel Machine Screw	903025
108	2	Oil Wick, .09 x .09	1191430
109	1	#4-40 x 1/8" Long Pan Head Stainless Steel Machine Screw	1191260
*110	1	Ball Bearing, Top Wormwheel Shaft	908660
*111	1	Ball Bearing, Bottom Wormwheel Shaft	905462
*112	1	Ball Bearing, Downstream Rotor Shaft	950235
*113	1	Ball Bearing, Upstream Rotor Shaft	950236
114	1	Switch Assembly	006-34-134-00
115	4	#2-56 x 1/8" Hexagonal Stainless Steel Set Screw, Nylon Locking	950218
116	1	#0-80 x 5/16" Flat Head Stainless Steel Machine Screw	950238
117	2	#5-40 x 1/4" Round Head Stainless Steel Machine Screw	903033
118	3	#2-56 x 1/4" Round Head Stainless Steel Machine Screw	950239
119	1	Locknut	904168
†120	1	Carrier Assembly (Includes Illustration Nos. 120-129)	AAT-18 006-32-519-03
		Carrier Assembly (Includes Illustration Nos. 120-129)	AAT-27 006-42-519-03
†121	1	Bearing Bracket Carrier, Without Heli Coil Inserts	006-32-019-05
122	2	Filter Screen	006-22-083-01
123	2	Retaining Ring	904419
124	1	Oil Tube	006-32-079-01
125	1	Shield Tube	006-32-082-01
126	1	Pressure Tap Tube	AAT-18 006-32-079-04
127	3	Vane Inserts	006-32-025-00
128	3	#6-32 x 1/4" Long Machine Screw	950585
129	4	Module Seal Positioner	950754
130	3	#5-40 x 7/16" Fillister Head Stainless Steel Machine Screw	950243
*131	1	"O" Ring	950318
132	5	#5 Internal Lockwasher, Stainless Steel	950374
133	3	#2 Internal Lockwasher, Stainless Steel	904022
134	2	#4 External Lockwasher, Stainless Steel	950078
*135	1	Seal-Oil Passage	006-36-160-09
136	1	#4-40 x 1/8" Long Stainless Steel Set Screw, Nylon Locking	950305

*Recommended Spare Parts

†These items affect calibration and must be ordered in combination with Sensor Rotor Assembly, Decoupling (Center) Plate and Internal Housing, as a 302 Assembly.

4" MODEL AAT-18 AND AAT-27 AUTO-ADJUST® II TURBO-METERS

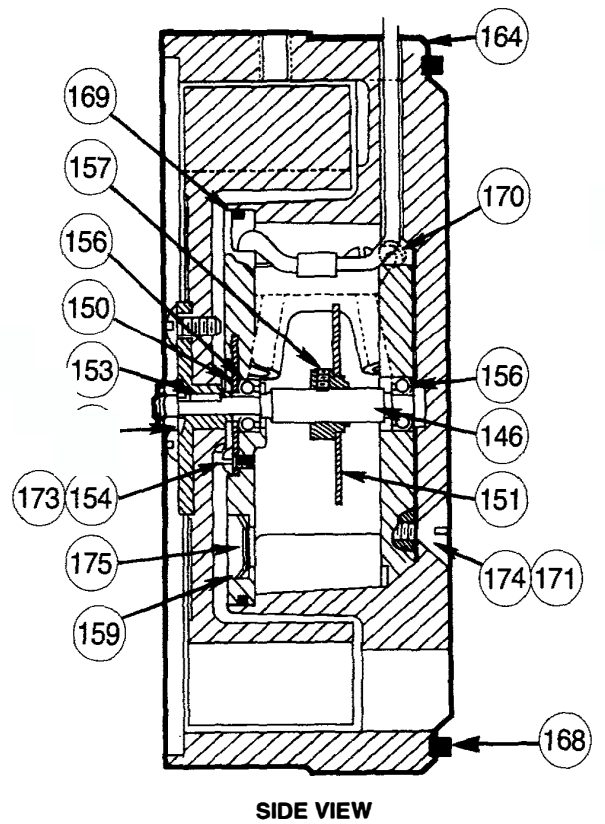
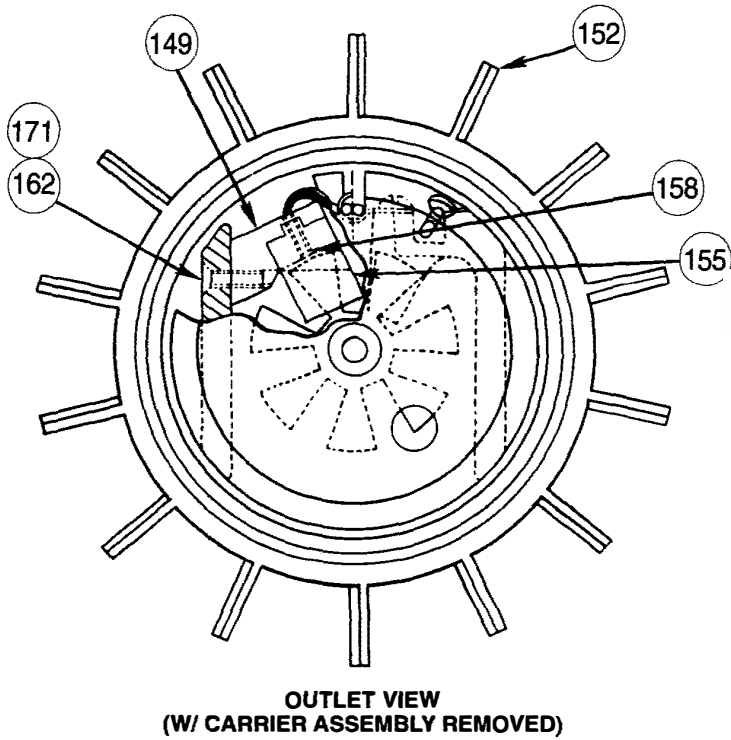
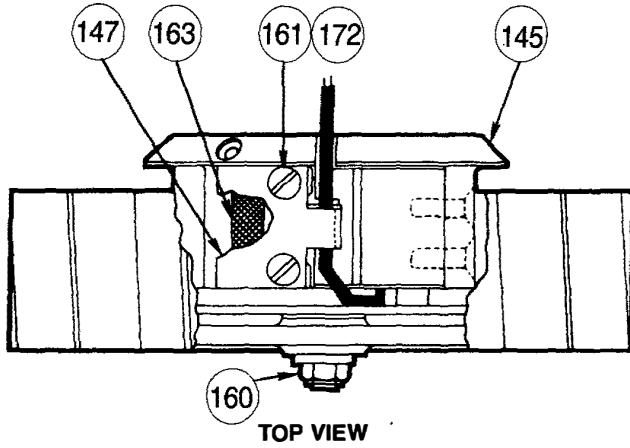

Sensing Rotor Assembly Components

ILL. NO.	QTY. REQ'D	PART DESCRIPTION	PART NUMBER
†	1	Sensing Rotor Assembly (Includes Illustration Nos. 145-175)	AAT-18 006-32-550-03
		Sensing Rotor Assembly (Includes Illustration Nos. 145-175)	AAT-27 006-42-550-03
145	1	Bearing Bracket	006-32-021-01
146	1	Sensing Rotor Shaft	006-32-024-01
147	1	Oil Wick Cover	006-32-053-00
148	1	Spherical Washer	006-32-077-00
149	1	Slot Sensor Holder	006-32-078-00
150	1	Bearing Retainer	006-32-117-00
151	1	Chopper Assembly (Includes Illustration No. 157)	006-32-308-01
†152	1	Rotor & Hub Assembly	AAT-18 006-32-350-03
		Rotor & Hub Assembly	AAT-27 006-42-350-03
153	1	Locking Pin	006-22-020-00
154	3	#2-56 x 1/8" Round Head Stainless Steel Machine Screw	950260
155	1	Switch Assembly	950563
* 156	2	Ball Bearing for Rotor Shaft	950241
157	1	#4-40 x 1/8" Cup Point Stainless Steel Set Screw, Nylon Locking	950305
158	1	#0-80 x 5/16" Flat Head Stainless Steel Machine Screw	950238
159	3	Retaining Ring	904419
160	1	Locknut	904168
161	2	#4-40 x 1/4" Round Head Stainless Steel Machine Screw	903025
162	2	#4-40 x 3/8" Flat Head Stainless Steel Machine Screw	950259
163	1	Oil Wick, .09 x .09	1191430
†164	1	Carrier Assembly [Includes Illustration Nos. 165, 168, (1) 159, and (1) 175]	006-32-519-02
165	1	Oiling Tube (Not Shown)	006-32-079-01
168	1	Tetraseal, Viton	950479
* 169	1	"O" Ring	950318
* 170	1	"O" Ring, Buna	950317
171	5	#4 C Sink, External Lockwasher	950377
172	2	#4 External Lockwasher, Stainless Steel	950078
173	3	#2 Internal Lockwasher, Stainless Steel	904022
174	3	#4-40 x 1/4" Long Flat Head Stainless Steel Machine Screw	903110
175	3	Filter Screen, Stainless Steel	006-22-083-01
176	AR	Oil, 4 oz. Bottle (Not Shown)	006-22-405-01
177	AR	Oil, 1 gal. Can (Not Shown)	006-22-405-02
178	AR	Lubrication Hand Gun (Not Shown)	006-24-400-00

*Recommended Spare Parts

†These items affect calibration and must be ordered in combination with Main Rotor Assembly, Decoupling (Center) Plate and Internal Housing, as a 302 Assembly.

4" MODEL AAT-18 AND AAT-27 AUTO-ADJUST® II TURBO-METERS

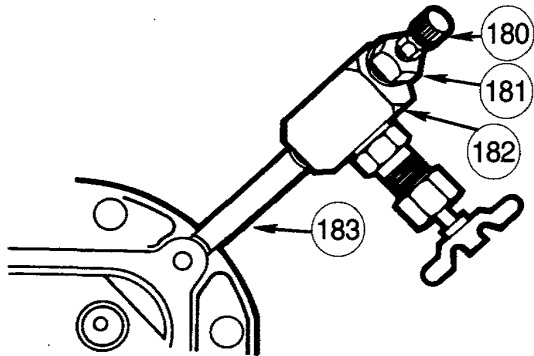

TOP PLATE

External Lubrication System Fittings

ILL. NO.	QTY. REQ'D	PART DESCRIPTION	PART NUMBER
180	1	Lubrication Gun Fitting	907887
181	1	Hex Bushing	950759
182	1	Valve, 1/4" Carbon Steel H.P.	950710
		Valve, 1/4" Brass, #175 W.P.	950428
183	1	Pipe Nipple, 1/4" x 3" Steel H.P.	950760
		Nipple, 1/4" x 1/4" Brass #175 W.P.	904765

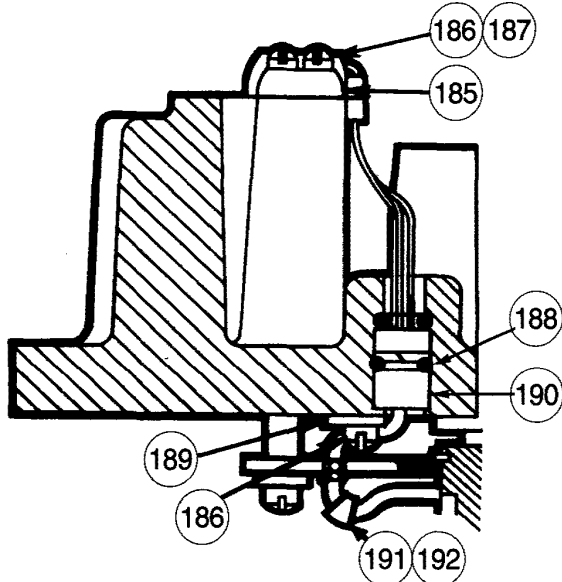

TOP PLATE SECTION

Electrical System Fittings

ILL. NO.	QTY. REQ'D	PART DESCRIPTION	PART NUMBER
185	1	Terminal Block	950364
186	3	#8-32 x 3/8" Long Fillister Head Stainless Steel Machine Screw	903371
187	4	External Lock Washer	950371
188	2	"O" Ring	946881
		"O" Ring Viton	902418
189	1	#8 Stainless Steel Washer	950448
190	1	Feed-through Assembly	950588
		Feed-through Assembly, Viton	006-32-317-00
191	AR	Solder, Bar Form, 50/50, 1/4" dia., 2" pc.	750155
192	AR	Shrink Tube	800633

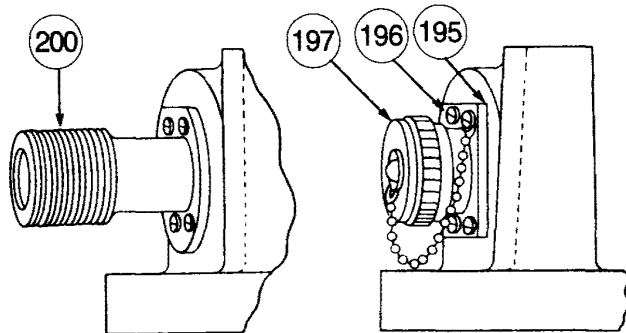

CONDUIT TYPE

PLUG-IN TYPE

External Wiring Fittings

ILL. NO.	QTY. REQ'D	PART DESCRIPTION	PART NUMBER
195	1	Gasket	905321
196	4	#8-32 x 1/4" Long Round Head Stainless Steel Machine Screw	903055
197	1	Cap & Chain Assembly for Plug-in Connector	006-32-131-00
198	1	Plug-in Connector, Female End (Not Shown)	950388
199	1	Plug-in Connector, Male End With Wiring To Terminal Block	006-34-250-0
200	1	Conduit Adapter Assembly, 1/2"-14 NPT With Wiring To Terminal Block	006-34-330-00

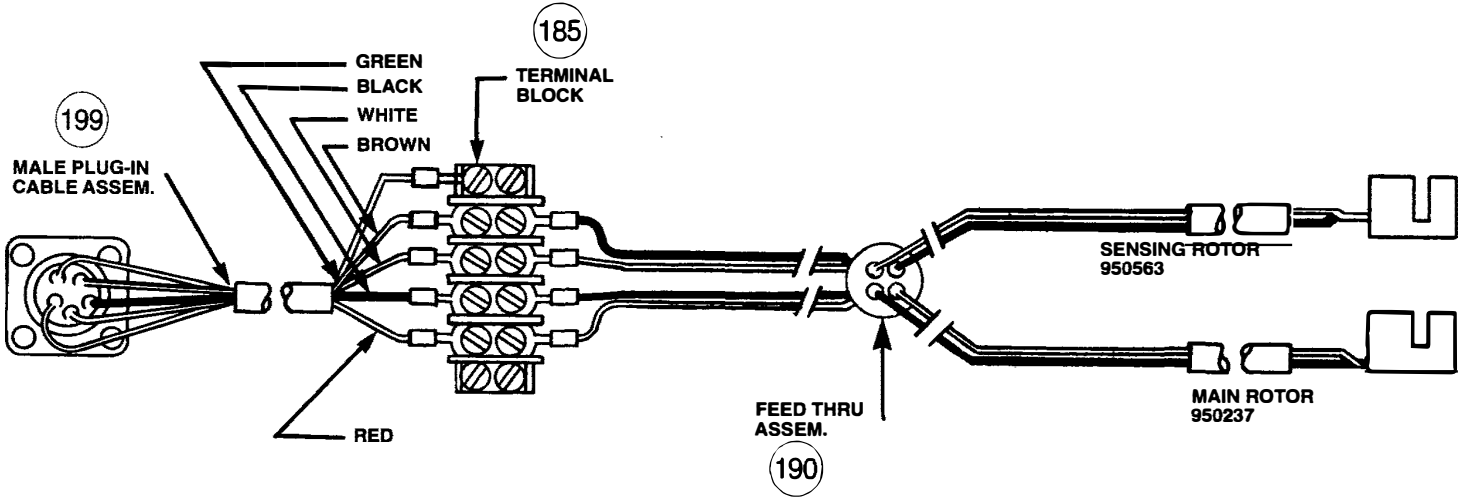

AAT-18 and AAT-27 TURBO-METER WIRING SYSTEM COMPONENTS

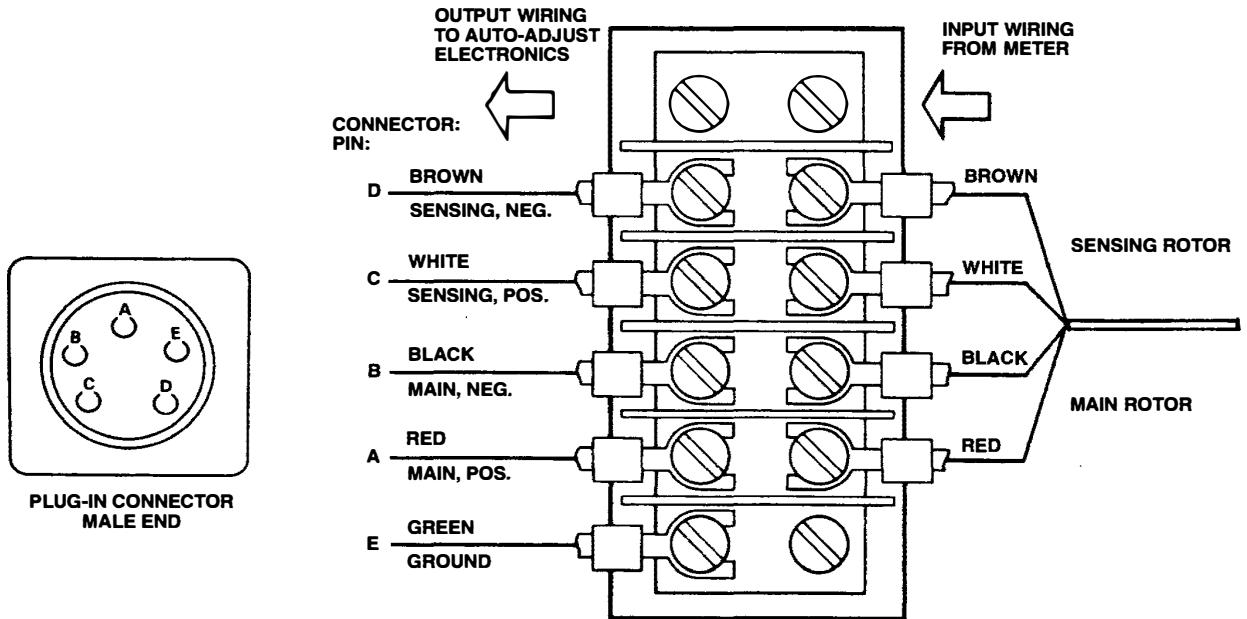

TERMINAL BLOCK WIRING DETAIL
(FOR PLUG-IN OR CONDUIT TYPE CONNECTORS)



805 Liberty Boulevard
DuBois, PA 15801
814-375-8875
Fax 814-375-8460

Authorized Distributor

Limited Warranty

Seller warrants the Goods to be free from defects in materials manufactured by Seller and in Seller's workmanship for a period of one (1) year after tender of delivery (the "Warranty Period"). THIS LIMITED WARRANTY (a) IS IN LIEU OF, AND SELLER DISCLAIMS AND EXCLUDES ALL OTHER WARRANTIES, STATUTORY, EXPRESS OR IMPLIED, INCLUDING, WITH LIMITATION, ANY WARRANTY OF MERCHANTABILITY OR FITNESS FOR A PARTICULAR PURPOSE, OR OF CONFORMITY TO MODELS OR SAMPLES; (b) does not apply to any Goods which have been (i) repaired, altered or improperly installed; (ii) subjected to improper use or storage, (iii) used or incorporated with other materials or equipment, after buyer or anyone using the Goods has, or reasonably should have, knowledge of any defect or nonconformance of the Goods; or (iv) manufactured, fabricated or assembled by anyone other than Seller, (c) shall not be effective unless buyer notifies Seller in writing of any purported defect or nonconformance with (thirty days) after Buyer discovers or should have reasonably discovered such purported defect or nonconformance; and (d) shall only extend to Buyer and not to any subsequent buyers or users of the Goods. Buyer shall provide Seller access to the Goods as to which Buyer claims a purported defect or nonconformance, upon request by Seller, buyer shall, at its own risk and expense, promptly return the Goods in question to Seller's Plant.